

EE-F9

4.0 Ton 2 Post Base Plate Hoist



» 4.0 Ton lifting capacity

» Lifting height of 1.85m plus 4WD adapters

» Base plate design

» Durable charcoal Hammertone powder coat finish, with orange arms

» Single lock release

» Door protection pads

» Combination screw pads plus 4WD adapters

» 5 Years Structural, 1 Year electrical, parts & labour warranty

» Certified to Australian Standards and design registered with Worksafe

INCLUSIONS



Hydraulic Oil



Screw Pad /
4WD Adapter



Arm Tool Tray

OPTIONS



EV Charging
Station



Tyre Holder
Adapter



EAE
Low Profile Arm

EE-F9

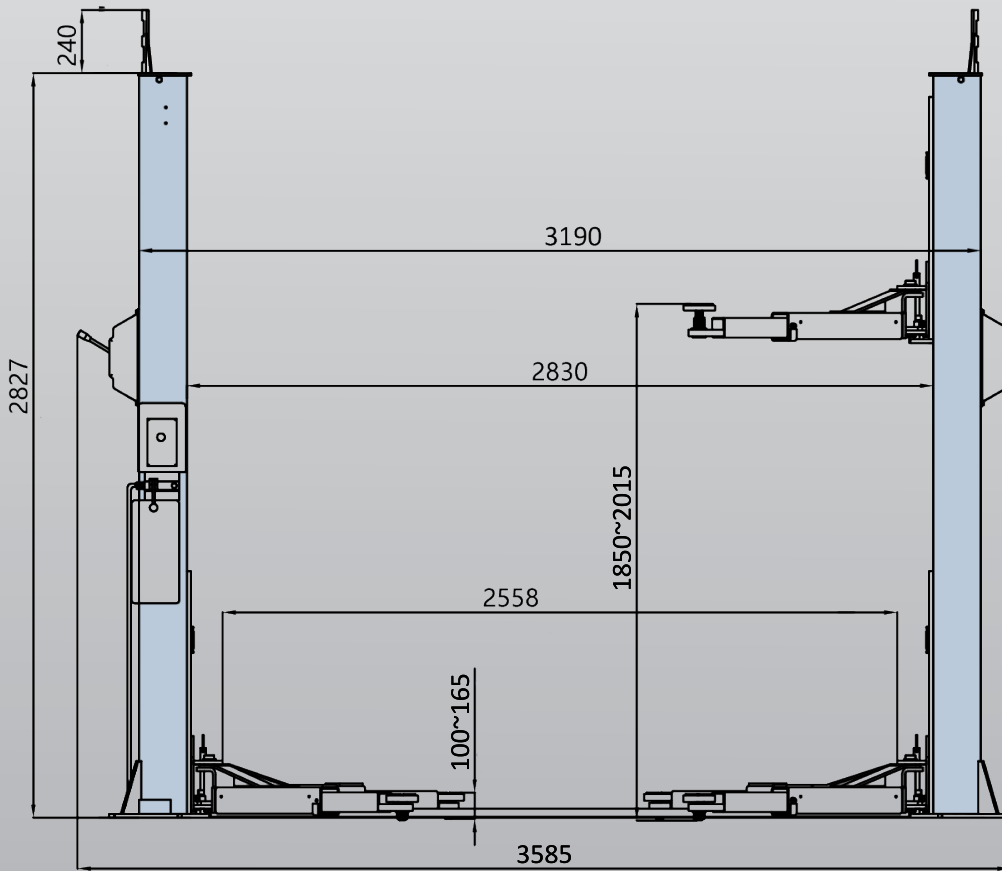

Minimum Concrete Requirement
115mm
Recommended Ceiling Height
3.25m
Power Requirements
240v
2.2kw 16 amps
3 phase
3.5kw 9 amps
Fast motor
Neutral required
Freight Dimensions
286 x 57 x 100cm
672kg

