

# EE-F10

## 4.5 Ton 2 Post Base Plate Hoist

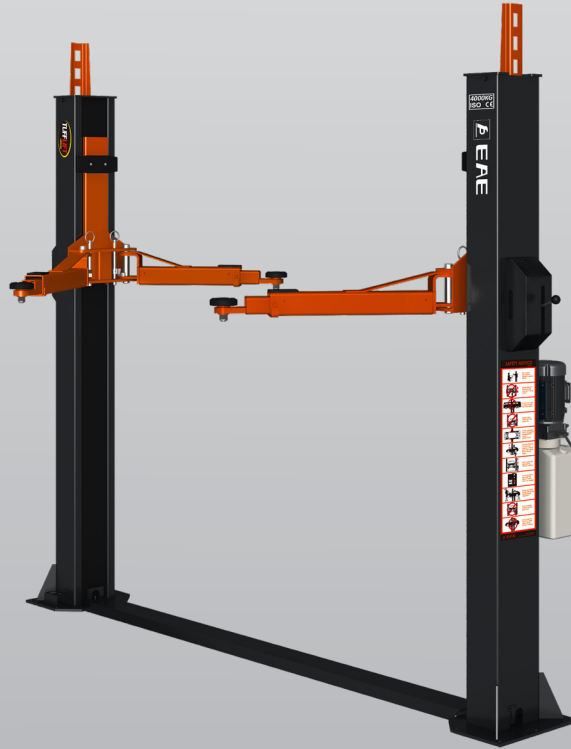

- » 4.5 Ton lifting capacity
- » Lifting height of 1.85m plus 4WD adapters
- » Base plate design
- » Durable charcoal Hammertone powder coat finish, with orange arms
- » Single lock release
- » Door protection pads
- » Combination screw pads plus 4WD adapters
- » 5 Years Structural, 1 Year electrical, parts & labour warranty
- » Certified to Australian Standards and design registered with Worksafe

### INCLUSIONS



Hydraulic Oil



Screw Pad /  
4WD Adapter



Arm Tool Tray

### OPTIONS



EV Charging  
Station



Tyre Holder  
Adapter



EAE  
Low Profile Arm

# EE-F10

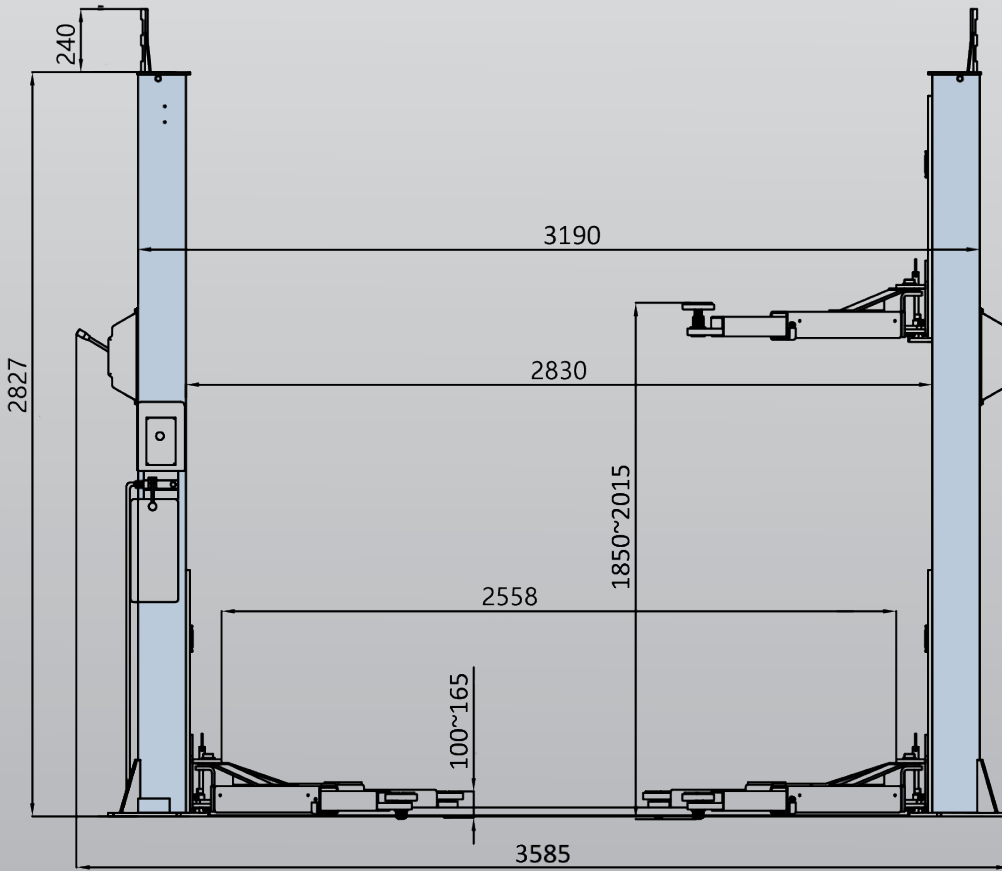

<b>Minimum Concrete Requirement</b>
150mm
<b>Recommended Ceiling Height</b>
3.25m
<b>Power Requirements</b>
240v
2.2kw 16 amps
3 phase
3.5kw 9 amps
Fast motor
Neutral required
<b>Freight Dimensions</b>
290 x 56 x 110cm
730kg

